

New type

# NRS Gate Valve

BS5163

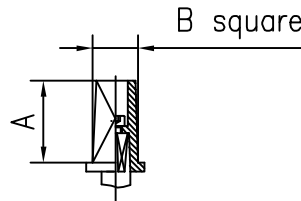
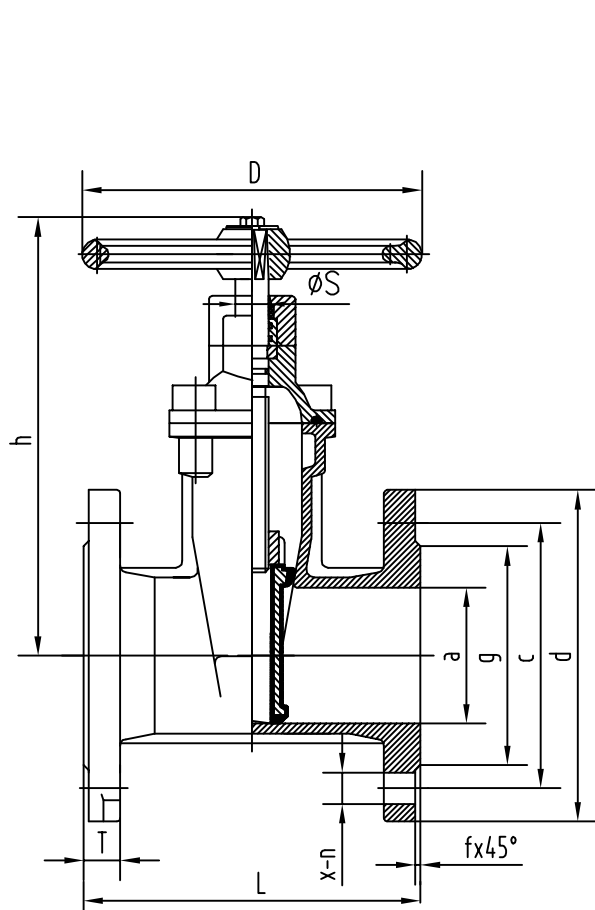

### SPECIFICATIONS

Size	DN 40 - 300
Class	PN 10 - PN 16
Design	BS5163
Face to Face	BS5163-PN10/16
End Flange	BS EN 1092
Test	BS5163
Working Temperature	NBR ≤80°C EPDM ≤120°C

### STANDARD MATERIALS OF MAIN PARTS

ITEM	PART NAME	MATERIAL
1	Body	Ductile Iron
2	Disc	Ductile Iron+NBR / EPDM
3	Bonnet	Ductile Iron
4	Stem	Stainless Steel 420
5	Stem Nut	Brass
6	Holding Ring	Brass
7	Sealing Ring	Brass
8	Handwheel	Ductile Iron
9	Bonnet Gasket	EPDM
10	O Ring	NBR
11	Dust Ring	NBR

### Dimensions of stem caps and keys

DN	A	B
50-300	63	35
350-600	75	48

### DIMENSIONS AND WEIGHTS

DN	OUTLINE mm				END FLANGE DIN PN10/16 mm										
	L	h	D	h1	a	d	C		x-n	T	g	f	øS		
40	165	190	150	235	40	150	110		4-ø19	19	84	3	18		
50	178	205	150	250	50	165	125		4-ø19	19	99	3	18		
65	190	228	150	275	65	185	145		4-ø19	19	118	3	18		
80	203	285	180	310	80	200	160		8-ø19	19	132	3	20		
100	229	300	205	345	100	220	180		8-ø19	19	156	3	20		
125	254	355	205	400	125	250	210		8-ø19	19	184	3	24		
150	267	400	240	445	150	285	240		8-ø23	19	211	3	24		
200	292	490	280	545	200	340	295		8-ø23	12-ø23	20	266	3	26	
250	330	585	320	640	250	395	405	350	355	12-ø23	12-ø28	22	319	3	30
300	356	685	360	740	300	445	460	400	410	12-ø23	12-ø28	24.5	370	4	36