

Resilient Gate Valve

BS 5163

SPECIFICATIONS

Size	DN350-600
Class	PN16
Design	BS5163
Face to Face	BS5163-PN16
End Flange	BS EN 1092
Test	BS5163
Working Temperature	NBR ≤80 °C

STANDARD MATERIALS OF MAIN PARTS

ITEM	PART NAME	MATERIAL
1	Body	Ductile Iron
2	Disc	Ductile iron+NBR
3	Bonnet	Ductile Iron
4	Stem	Stainless Steel 420
5	Stem Nut	Brass
6	Holding Ring	Brass
7	Sealing Ring	Brass
8	Handwheel	Ductile Iron
9	Bonnet Gasket	NBR
10	O Ring	NBR
11	Dust Ring	NBR

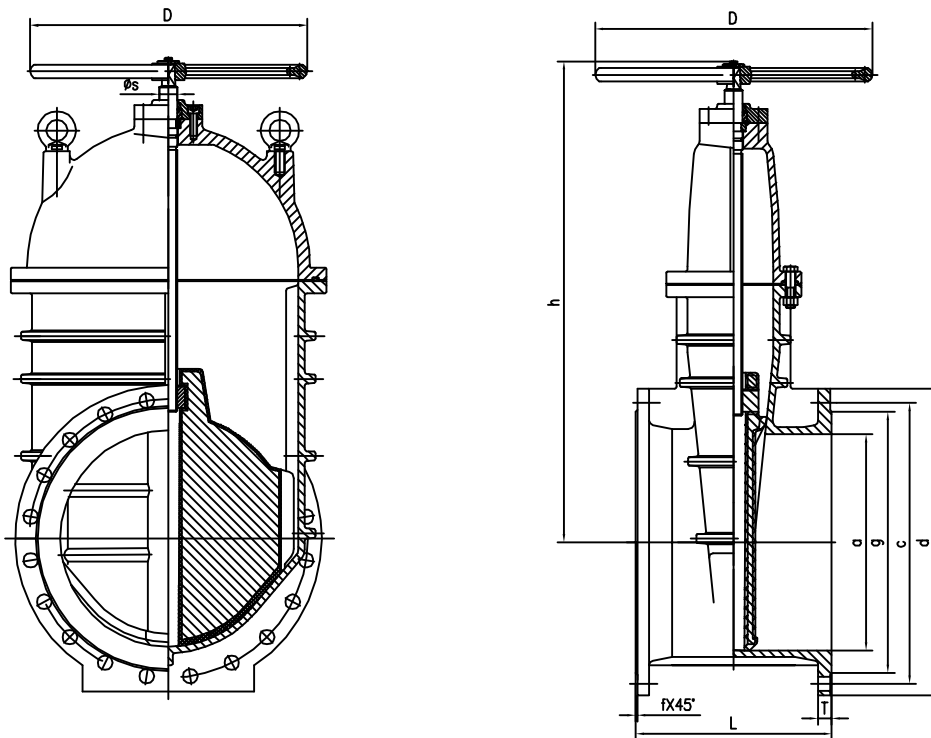

DIMENSIONS AND WEIGHTS

DN	OUTLINE mm			END FLANGE DIN PN10/16 mm											
	L	h	D	a	d	c	x-n	T	g	f	øS				
350	381	845	500	350	505	520	460	470	16-ø23	16-ø28	26.5	429	4	42	
400	406	940	560	400	565	580	515	525	16-ø28	16-ø31	28	480	4	42	
450	432	1005	560	450	615	640	565	585	20-ø28	20-ø31	30	530	548	4	42
500	457	1100	650	500	670	715	620	650	20-ø28	20-ø34	31.5	582	609	4	42
600	508	1285	650	600	780	840	725	770	20-ø31	20-ø37	36	682	720	5	42