

Gate Valve DN350-DN600 Gear Box

DIN3352 F5

SPECIFICATIONS

Size	DN350-600
Class	PN16
Design	DIN3352
Face to Face	DIN 3202 F5
End Flange	BS EN 1092
Test	DIN3230
Working Temperature	NBR ≤80°C

STANDARD MATERIALS OF MAIN PARTS

ITEM	PART NAME	MATERIAL
1	Body	Ductile Iron
2	Disc	Ductile iron+NBR
3	Bonnet	Ductile Iron
4	Stem	Stainless Steel 420
5	Stem Nut	Brass
6	Holding Ring	Brass
7	Sealing Ring	Brass
8	Handwheel	Ductile Iron
9	Bonnet Gasket	NBR
10	O Ring	NBR
11	Dust Ring	NBR

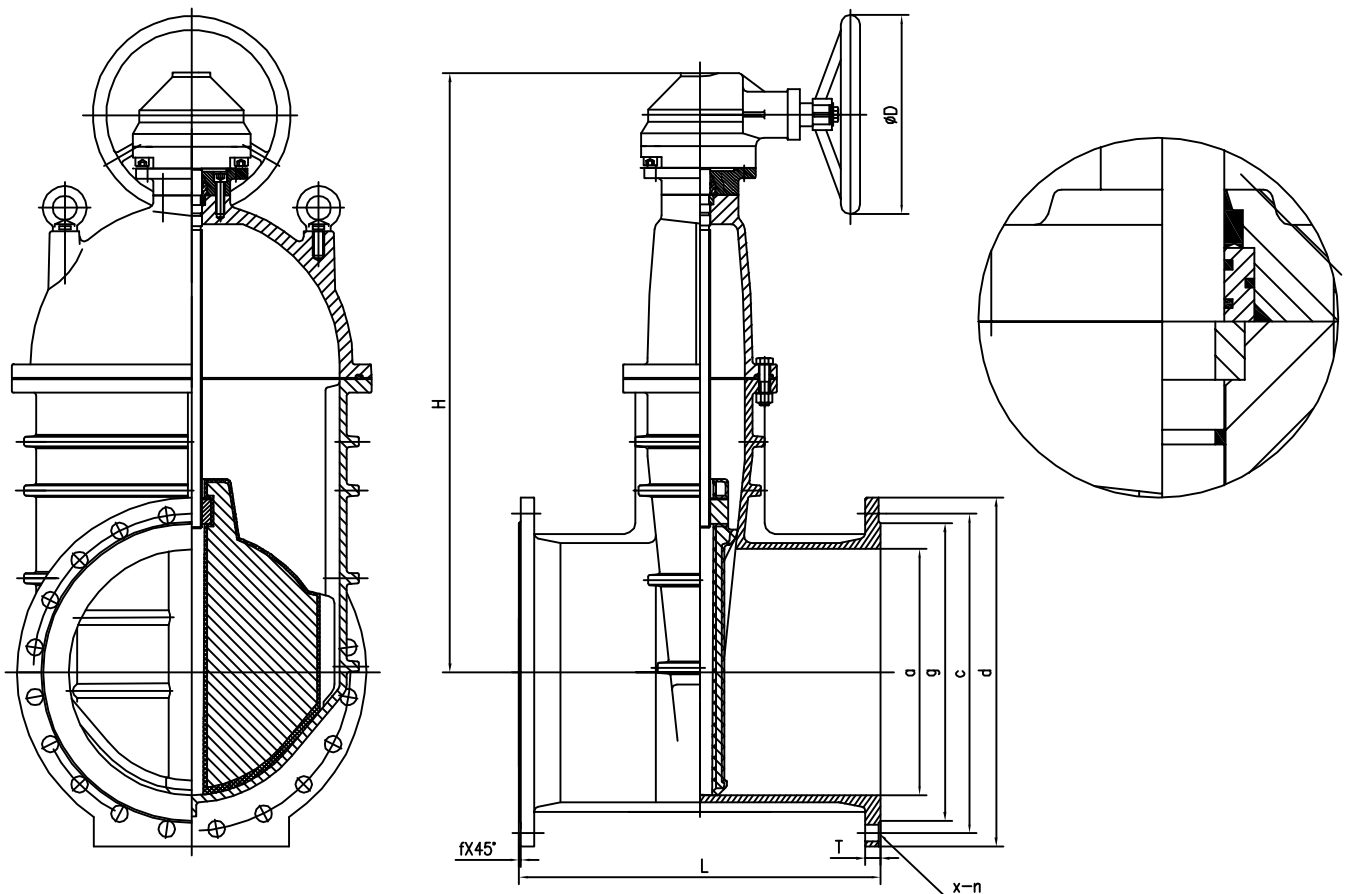

DIMENSIONS AND WEIGHTS

DN	OUTLINE mm			END FLANGE DIN PN10/16 mm									
	L	H	∅D	a	d	c	x-n	T	g	f			
350	550	920	310	350	520	460	470	16-∅23	16-∅28	26.5	429	4	
400	600	1010	310	400	580	515	525	16-∅28	16-∅31	28	480	4	
450	650	1110	460	450	640	565	585	20-∅28	20-∅31	30	530	548	4
500	700	1205	460	500	715	620	650	20-∅28	20-∅34	31.5	582	609	4
600	800	1390	460	600	840	725	770	20-∅31	20-∅37	36	682	720	5