

# Gate Valve DN350-DN600 Hand Wheel

DIN3352 F5

## SPECIFICATIONS

Size	DN350-600
Class	PN16
Design	DIN3352
Face to Face	DIN 3202 F5
End Flange	BS EN 1092
Test	DIN3230
Working Temperature	NBR ≤80°C

## STANDARD MATERIALS OF MAIN PARTS

ITEM	PART NAME	MATERIAL
1	Body	Ductile Iron
2	Disc	Ductile iron+EPDM
3	Bonnet	Ductile Iron
4	Stem	Stainless Steel 420
5	Stem Nut	Brass
6	Holding Ring	Brass
7	Sealing Ring	Brass
8	Handwheel	Ductile Iron
9	Bonnet Gasket	NBR
10	O Ring	NBR
11	Dust Ring	NBR

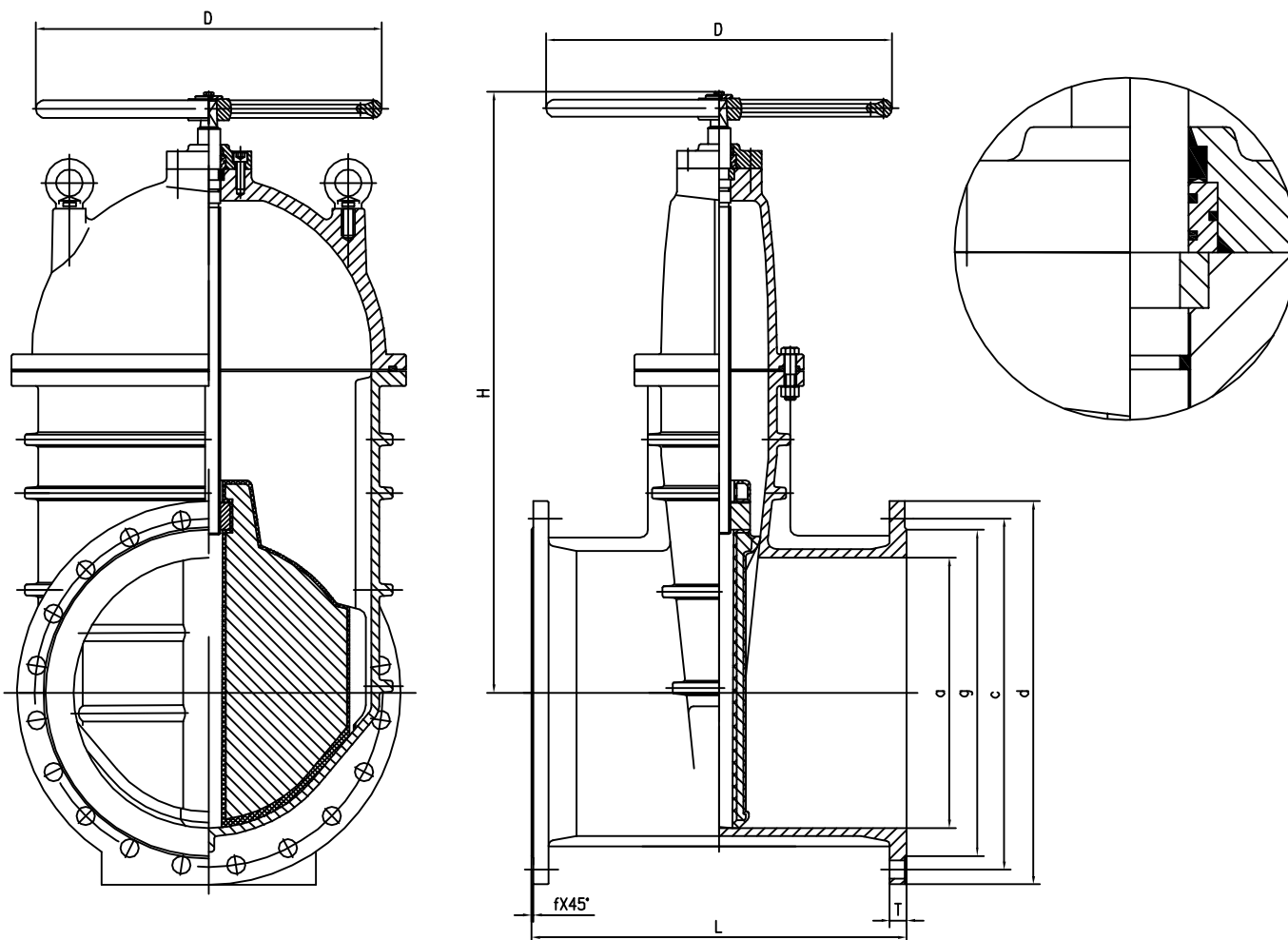

## DIMENSIONS AND WEIGHTS

DN	OUTLINE mm			END FLANGE DIN PN10/16 mm									
	L	h	D	a	d	c	x-n		T	g	f		
350	550	845	500	350	520	460	470	16- $\phi$ 23	16- $\phi$ 28	26.5	429	4	
400	600	940	560	400	580	515	525	16- $\phi$ 28	16- $\phi$ 31	28	480	4	
450	650	1005	560	450	640	565	585	20- $\phi$ 28	20- $\phi$ 31	30	530	548	4
500	700	1100	650	500	715	620	650	20- $\phi$ 28	20- $\phi$ 34	31.5	582	609	4
600	800	1285	650	600	840	725	770	20- $\phi$ 31	20- $\phi$ 37	36	682	720	5