

# Gate Valve DN350-DN600 Gear Box

# DIN3352 F4

## SPECIFICATIONS

Size	DN350-600
Class	PN16
Design	DIN3352
Face to Face	<b>DIN 3202 F4</b>
End Flange	BS EN 1092
Test	DIN3230
Working Temperature	NBR ≤80°C

## STANDARD MATERIALS OF MAIN PARTS

ITEM	PART NAME	MATERIAL
1	Body	Ductile Iron
2	Disc	Ductile iron+NBR
3	Bonnet	Ductile Iron
4	Stem	Stainless Steel 420
5	Stem Nut	Brass
6	Holding Ring	Brass
7	Sealing Ring	Brass
8	Handwheel	Ductile Iron
9	Bonnet Gasket	NBR
10	O Ring	NBR
11	Dust Ring	NBR

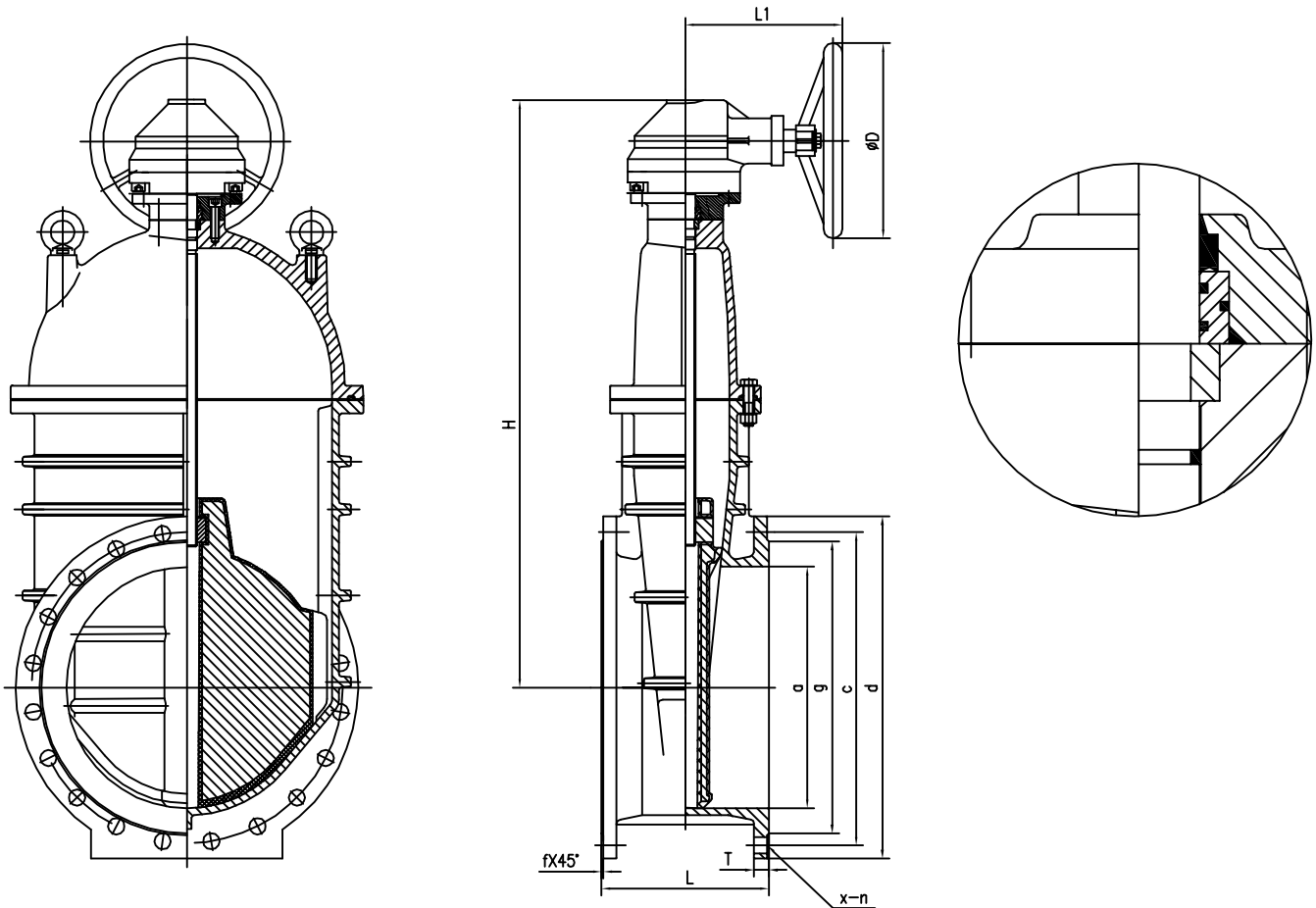

## DIMENSIONS AND WEIGHTS

DN	OUTLINE mm				END FLANGE DIN PN10/16 mm									
	L	H	øD	L1	a	d	c	x-n	T	g	f			
350	290	920	310	230	350	520	460	470	16-ø23	16-ø28	26.5	429	4	
400	310	1010	310	230	400	580	515	525	16-ø28	16-ø31	28	480	4	
450	330	1110	460	290	450	640	565	585	20-ø28	20-ø31	30	530	548	4
500	350	1205	460	290	500	715	620	650	20-ø28	20-ø34	31.5	582	609	4
600	390	1390	460	290	600	840	725	770	20-ø31	20-ø37	36	682	720	5