

Gate Valve DN40-DN300 Gear Box

DIN3352-F4

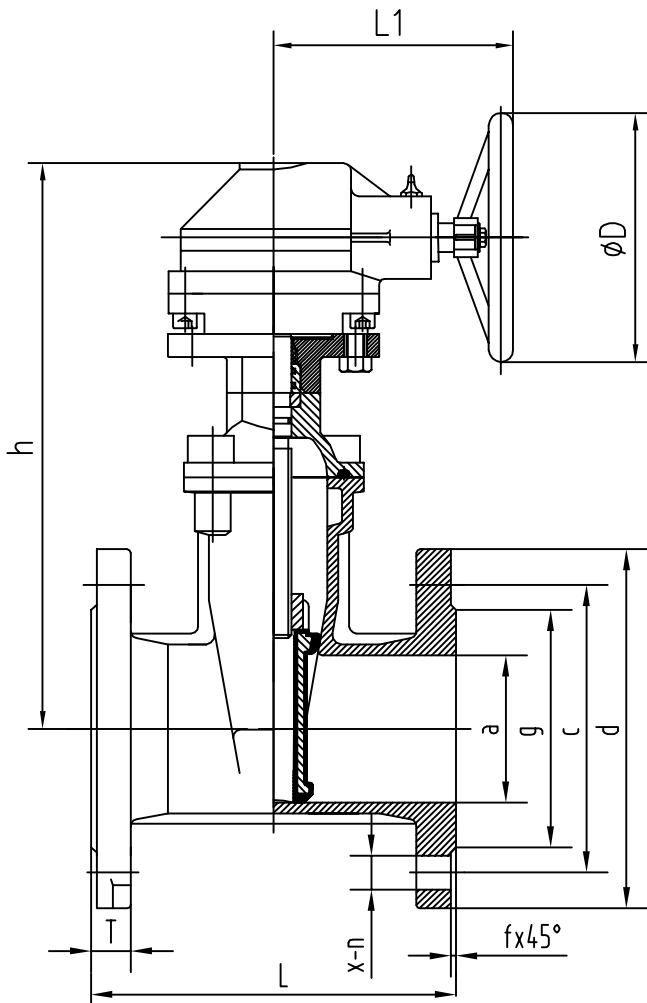

SPECIFICATIONS

Size	DN 40 - 300
Class	PN 10 - PN 16
Design	DIN3352
Face to Face	DIN3202-F4
End Flange	BS EN 1092
Test	DIN3230
Working Temperature	NBR ≤80°C
	EPDM ≤120°C

STANDARD MATERIALS OF MAIN PARTS

ITEM	PART NAME	MATERIAL
1	Body	Ductile Iron
2	Disc	Ductile Iron+NBR / EPDM
3	Bonnet	Ductile Iron
4	Stem	Stainless Steel 420
5	Stem Nut	Brass
6	Holding Ring	Brass
7	Sealing Ring	Brass
8	Top Flange	Ductile Iron
9	Bonnet Gasket	EPDM
10	O Ring	NBR
11	Dust Ring	NBR

DIMENSIONS AND WEIGHTS

DN	OUTLINE mm				END FLANGE DIN PN10/16 mm								
	L	h	D	L1	a	d	c	x-n		T	g	f	
40	140	268	200	175	40	150	110	4-Ø19		19	84	3	
50	150	288	200	175	50	165	125	4-Ø19		19	99	3	
65	170	313	200	175	65	185	145	4-Ø19		19	118	3	
80	180	338	200	175	80	200	160	8-Ø19		19	132	3	
100	190	373	200	175	100	220	180	8-Ø19		19	156	3	
125	200	433	200	175	125	250	210	8-Ø19		19	184	3	
150	210	473	200	175	150	285	240	8-Ø23		19	211	3	
200	230	570	260	205	200	340	295	8-Ø23	12-Ø23	20	266	3	
250	250	660	260	205	250	405	350	355	12-Ø23	12-Ø28	22	319	3
300	270	750	260	205	300	460	400	410	12-Ø23	12-Ø28	24.5	370	4