

Gate Valve DN40-DN300 Hand Wheel

DIN3352 F4

SPECIFICATIONS

Size	DN 40 - 300
Class	PN 10 - PN 16
Design	DIN 3352
Face to Face	DIN 3202 F4 / ISO 5752 14 Series
End Flange	DIN 2532-2533 / BS EN 1092
Test	DIN 3230

STANDARD MATERIALS OF MAIN PARTS

ITEM	PART NAME	MATERIAL
1	Body	Ductile Iron GGG50
2	Disc	Ductile Iron GGG50+ EPDM
3	Bonnet	Ductile Iron GGG50
4	Stem	Stainless Steel 420
5	Stem Nut	Brass
6	Holding Ring	Brass
7	Sealing Ring	Brass
8	Handwheel	Ductile Iron GGG50
9	Bonnet Gasket	NBR/EPDM
10	O Ring	NBR
11	Dust Ring	NBR

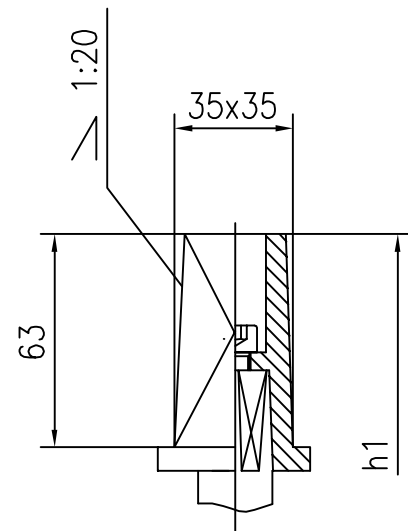
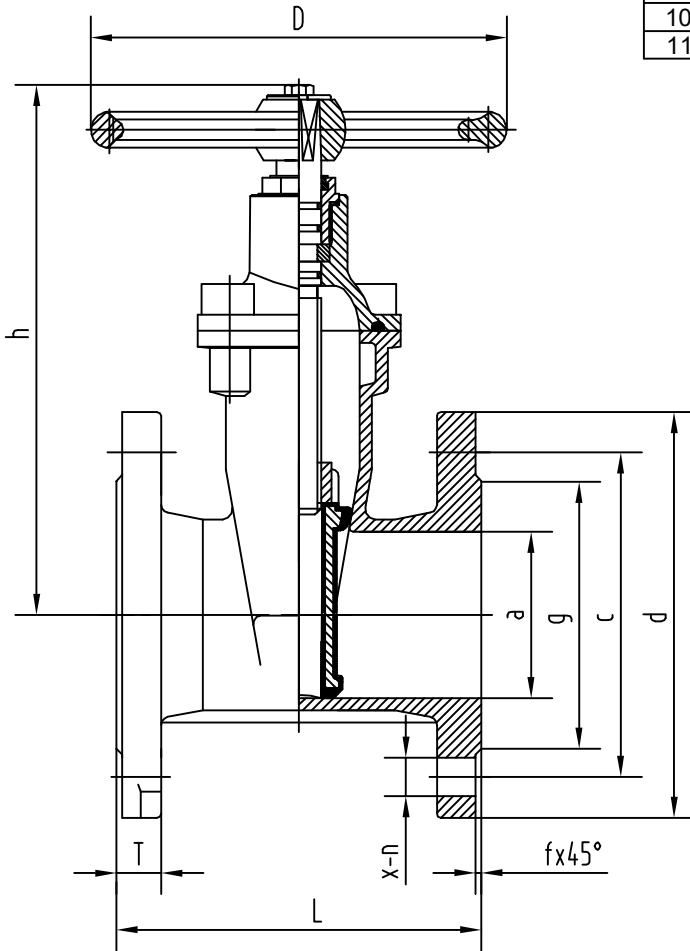

DIMENSIONS AND WEIGHTS

DN	OUTLINE mm				END FLANGE DIN PN10/16 mm								Weight (kg)
	L	h	D	h1	a	d	c	x-n	T	g	f		
40	140	190	150	235	40	150	110	4- ϕ 19	19	84	3	8.0	
50	150	205	150	250	50	165	125	4- ϕ 19	19	99	3	10.0	
65	170	228	150	275	65	185	145	4- ϕ 19	19	118	3	13.0	
80	180	265	180	310	80	200	160	8- ϕ 19	19	132	3	15.0	
100	190	300	205	345	100	220	180	8- ϕ 19	19	156	3	18.0	
125	200	355	205	400	125	250	210	8- ϕ 19	19	184	3	29.0	
150	210	400	240	445	150	285	240	8- ϕ 23	19	211	3	37.0	
200	230	490	280	545	200	340	295	8- ϕ 23	12- ϕ 23	20	266	3	52.0
250	250	585	320	640	250	405	350	12- ϕ 23	12- ϕ 28	22	319	3	83.0
300	270	685	360	740	300	460	400	12- ϕ 23	12- ϕ 28	24.5	370	4	125.0