

Gate Valve DN350-DN600 Hand Wheel

DIN3352 F4

SPECIFICATIONS

| | |
|---------------------|--------------------|
| Size | DN350-600 |
| Class | PN16 |
| Design | DIN3352 |
| Face to Face | DIN 3202 F4 |
| End Flange | BS EN 1092 |
| Test | DIN3230 |
| Working Temperature | NBR ≤80°C |

STANDARD MATERIALS OF MAIN PARTS

| ITEM | PART NAME | MATERIAL |
|------|---------------|-------------------------|
| 1 | Body | Ductile Iron GGG50 |
| 2 | Disc | Ductile iron GGG50+EPDM |
| 3 | Bonnet | Ductile Iron GGG50 |
| 4 | Stem | Stainless Steel 420 |
| 5 | Stem Nut | Brass |
| 6 | Holding Ring | Brass |
| 7 | Sealing Ring | Brass |
| 8 | Handwheel | Ductile Iron GGG50 |
| 9 | Bonnet Gasket | NBR |
| 10 | O Ring | NBR |
| 11 | Dust Ring | NBR |

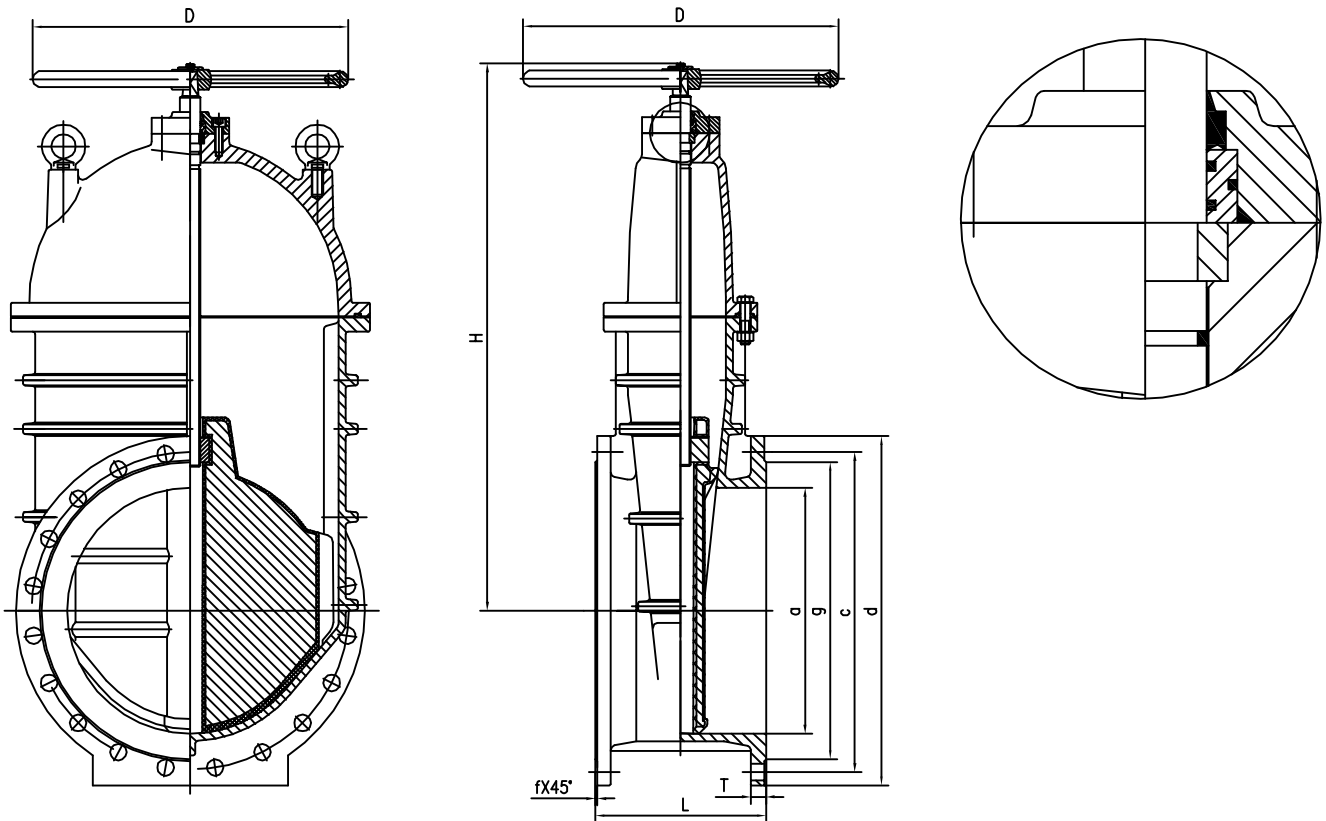

DIMENSIONS AND WEIGHTS

| DN | OUTLINE mm | | | END FLANGE DIN PN10/16 mm | | | | | | | | | |
|-----|------------|------|-----|---------------------------|-----|-----|-----|--------|--------|------|-----|-----|---|
| | L | h | D | a | d | c | x-n | T | g | f | | | |
| 350 | 290 | 845 | 500 | 350 | 520 | 460 | 470 | 16-ø23 | 16-ø28 | 26.5 | 429 | 4 | |
| 400 | 310 | 940 | 560 | 400 | 580 | 515 | 525 | 16-ø28 | 16-ø31 | 28 | 480 | 4 | |
| 450 | 330 | 1005 | 560 | 450 | 640 | 565 | 585 | 20-ø28 | 20-ø31 | 30 | 530 | 548 | 4 |
| 500 | 350 | 1100 | 650 | 500 | 715 | 620 | 650 | 20-ø28 | 20-ø34 | 31.5 | 582 | 609 | 4 |
| 600 | 390 | 1285 | 650 | 600 | 840 | 725 | 770 | 20-ø31 | 20-ø37 | 36 | 682 | 720 | 5 |